

# DT-041 In-Line Hydraulic Filter

Donaldson.

## Features

The DT-041 high flow filter combines the best features of a base-mounted assembly; several inlet port options, top cover element servicing for ease of maintenance, and a wide selection of service indicators. The DT-041 all-aluminum head design and plated steel cylinder provides a strong, durable, and dependable unit. We offer standard features like deep pleat elements for higher dirt holding capacity and our standard Donaldson Triboguard™ 5-layer media element construction. This technology, combined with many other standard features, is ideal for today's applications in pulp and paper, power generation, and steel mill applications. Five standard grades of media are offered. Thermal lockout and surge control are two key features incorporated in the differential indicators.

## Technical Data

Max. Working Pressure	500 psi (34.5 bar)
Rated Burst Pressure	1,500 psi max (103 bar)
Operating Temp. Range	-20° to 250°F (-29° to 121°C)
Head Material	Aluminum
Cap Material	Cast Iron
Weight	Assembly length 16": 48.5 lbs (22,0 kg)
	Assembly length 39": 86.2 lbs (39,2 kg)

**DT-041** series filter housing is a suitable replacement for competitor filter housings such as:

**Pall 8300, Schroeder QF5, Parker IL8, Hydac NFH, PTI F8G, Eaton HV6R**

**300 gpm (1135 l/min)**

**One diagnostic port in cover plus two drain ports in head for easy maintenance**

**Two  $\Delta P$  indicator options available**

**High strength bypass valve assembly for durable, reliable performance**

**Exceptional high dirt holding capacity**

**Large T-handle for fast servicing without tools**

**Fluorocarbon seals standard**



# DT-041 Performance Data

## Housing and Filter Element

Flow versus Pressure Drop  
150 SUS (32 cst.) oil with specific gravity  $\leq 0.9$

## Viscosity Correction Formula

$$\Delta P \text{ Element} = \Delta P \text{ from curve} \times \frac{\text{New Viscosity (SUS)}}{150} \times \frac{\text{New Specific Gravity}}{0.90}$$

$$\Delta P \text{ Housing} = \Delta P \text{ from curve} \times \frac{\text{New Specific Gravity}}{0.90}$$

$$\Delta P \text{ Assembly} = \Delta P \text{ Element} + \Delta P \text{ Housing}$$

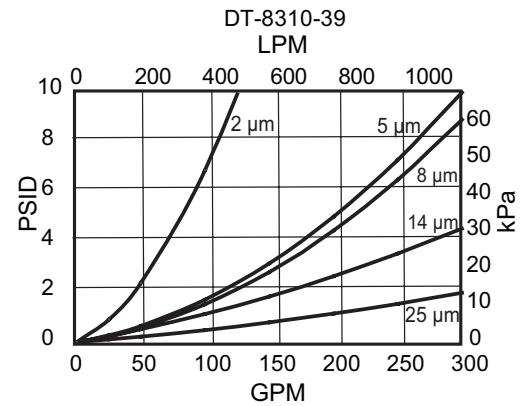
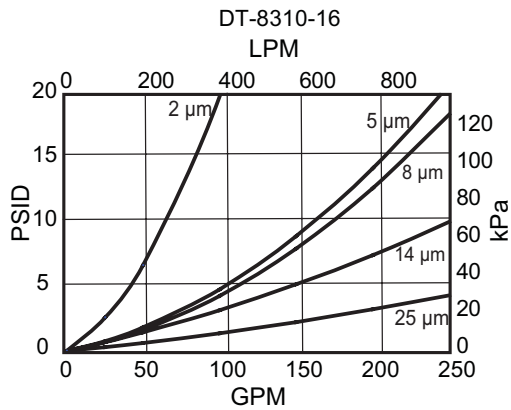
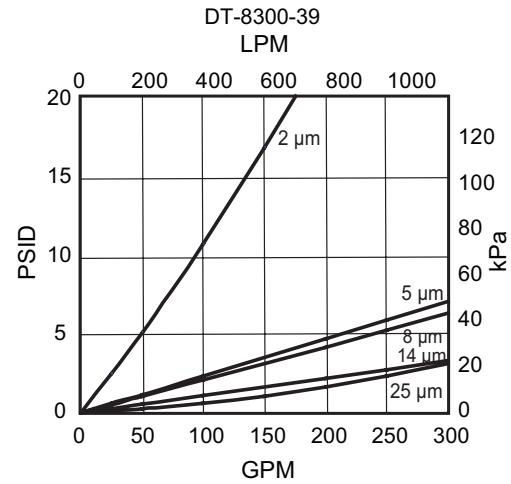
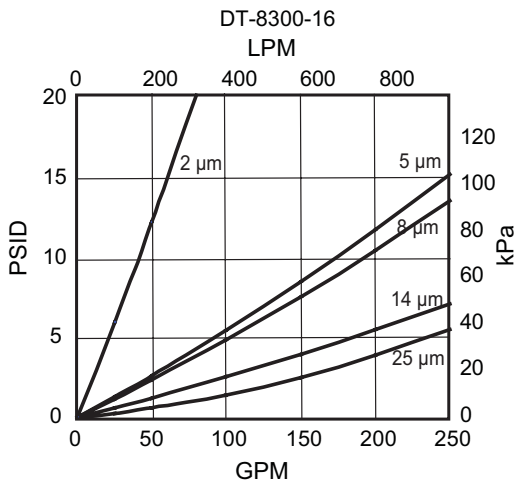
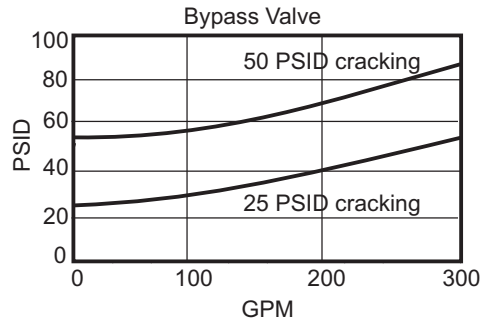
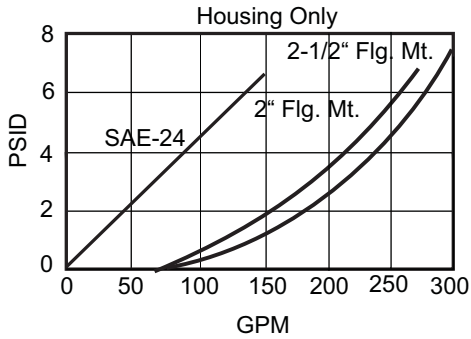

# DT-041 Ordering Code

## Example

Model	Housing Length	Bypass Valve	Indicator	Porting	Element Construction	Micron Rating
<b>DT-041</b>	2	A	D	J	A	02
	TABLE 1	TABLE 2	TABLE 3	TABLE 4	TABLE 5	TABLE 6

Housing shipped without element.

### Select one option from each table below.

(See example shown above.)

TABLE 1  
Housing Length

1	16"
2	39"

TABLE 2  
Bypass Valve

A	No bypass
B	50 psid bypass

TABLE 3  
Indicator

A	Visual Indicator 35 psid
C	Visual/Electrical 35 psid
B	Visual Indicator 70 psid
D	Visual/Electrical 70 psid
N	No indicator

TABLE 4  
Porting

D	SAE-24
H	2" Code 61 Four Bolt
J	2½" Code 61 Four Bolt

TABLE 5  
Element Construction

A	Standard (150 psid)
D	Extended Life (100 psid)

TABLE 6  
Micron Rating

02	Beta 1,000 at < 4 micron
05	Beta 1,000 at 5 micron
08	Beta 1,000 at 8 micron
14	Beta 1,000 at 14 micron
25	Beta 1,000 at 25 micron

**Please note:** Element selection to be ordered separately.

### Element Chart

Length	Construction	Micron Rating				
		02	05	08	14	25
1	A	DT-8300-16-2µm	DT-8300-16-5µm	DT-8300-16-8µm	DT-8300-16-14µm	DT-8300-16-25µm
	D	DT-8310-16-2µm	DT-8310-16-5µm	DT-8310-16-8µm	DT-8310-16-14µm	DT-8310-16-25µm
2	A	DT-8300-39-2µm	DT-8300-39-5µm	DT-8300-39-8µm	DT-8300-39-14µm	DT-8300-39-25µm
	D	DT-8310-39-2µm	DT-8310-39-5µm	DT-8310-39-8µm	DT-8310-39-14µm	DT-8310-39-25µm

## Electric Indicator (Aluminum Housings) Schematic Wiring Diagram

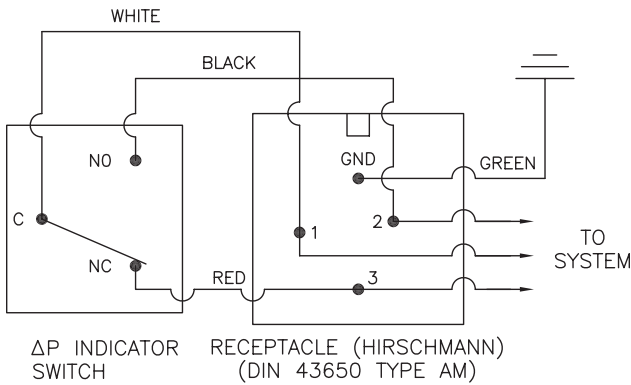

**Note:** The female plug (connector) is to be furnished by customer

### Differential Indicators

Indicators are designed to actuate at approximately 80% of bypass valve cracking pressure. It is recommended that an indicator with a bypass setting of 70 psid is used with a non-bypass housing.

### Surge Control

This optional feature is used to dampen pressure surges or spikes to avoid premature actuation of the indicator. Surge control delays the indicator response.

### Thermal Lockout

Thermal Lockout (TL), prevents actuation below 60°F and allows actuation above 100°F system operating temperature. Its purpose is to avoid false actuations during periods of high fluid viscosity such as experienced during cold start.

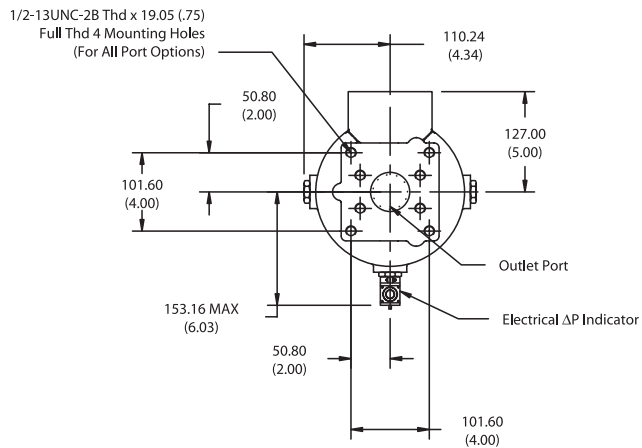
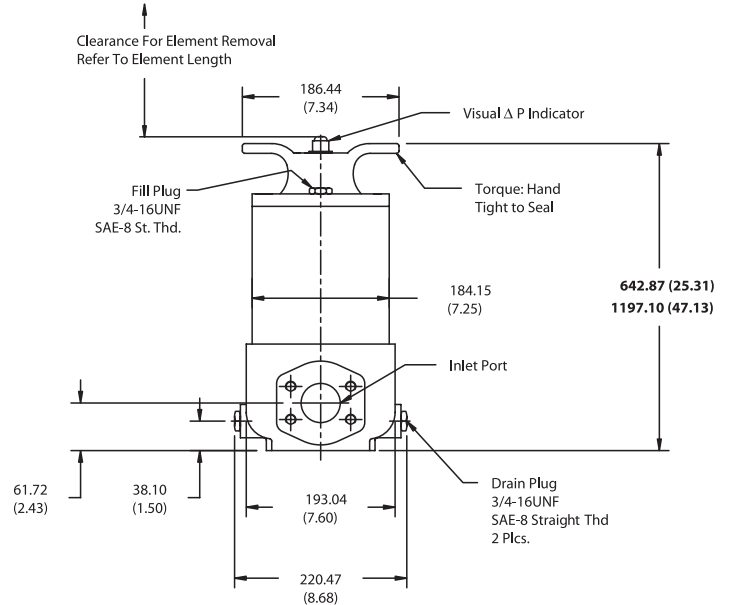

Dimensions: millimeter (inch)