

DT-042 In-Line Hydraulic Filter

Donaldson.

Features

DT-042 duplex filters insure continuous filtration is maintained while servicing elements, thus avoiding machine shutdown. The DT-042 all-aluminum head design and plated steel cylinders provide a strong, durable, and dependable unit. We offer standard features like deep pleat elements for higher dirt holding capacity and our standard Donaldson Triboguard™ 5-layer media element construction.

This technology, combined with many other standard features, is ideal for today's applications in pulp and paper, power generation, and steel mill applications. Five standard grades of media are offered. Thermal lockout and surge control are two key features incorporated in the differential indicators.

Technical Data

| | |
|------------------------|---|
| Max. Working Pressure | 400 psi (27.6 bar) |
| Typical Burst Pressure | 1,500 psi max (103.4 bar) |
| Operating Temp. Range | -20° to 250°F (-29° to 121°C) |
| Head Material | Aluminum |
| Cap Material | Cast Iron |
| Weight | Assembly length 16": 234 lbs (106,4 kg) |
| | Assembly length 39": 308 lbs (140 kg) |

DT-042 series filter housing is a suitable replacement for competitor filter housings such as:

Pall 8300, Schroeder QF5, Parker IL8, Hydac NFH, PTI F8G, Eaton HV6R

300 gpm (1135 l/min)

Hydrostatically-balanced, cam-operated, positive sealing valve for low torque shifting

Dual poppet outlet checks for positive isolation during element replacement

Two ΔP indicator ports

One diagnostic port in cover plus two drain ports in head for easy maintenance

Fluorocarbon seals standard



DT-042 Performance Data

Housing and Filter Element

Flow versus Pressure Drop
150 SUS (32 cst.) oil with specific gravity ≤ 0.9

Viscosity Correction Formula

$$\Delta P \text{ Element} = \Delta P \text{ from curve} \times \frac{\text{New Viscosity (SUS)}}{150} \times \frac{\text{New Specific Gravity}}{0.90}$$

$$\Delta P \text{ Housing} = \Delta P \text{ from curve} \times \frac{\text{New Specific Gravity}}{0.90}$$

$$\Delta P \text{ Assembly} = \Delta P \text{ Element} + \Delta P \text{ Housing}$$

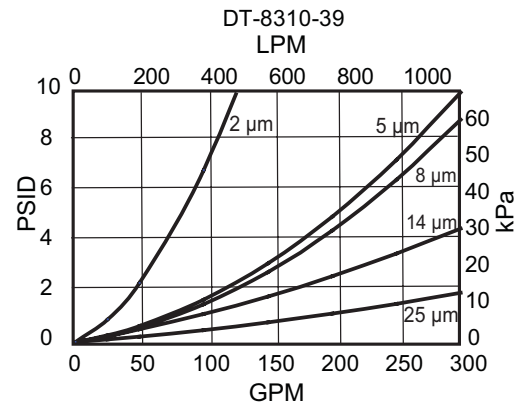
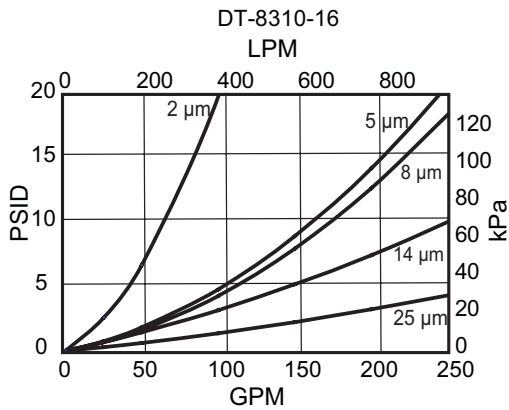
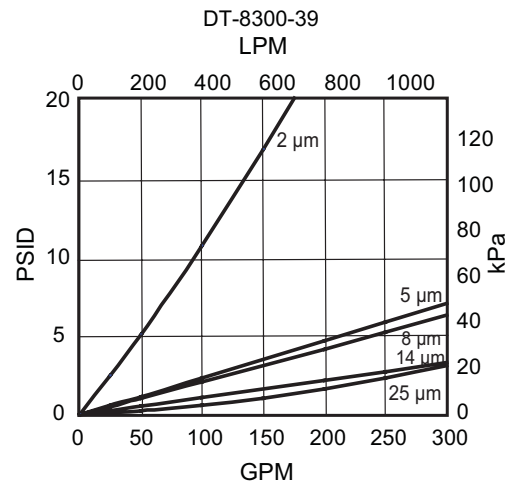
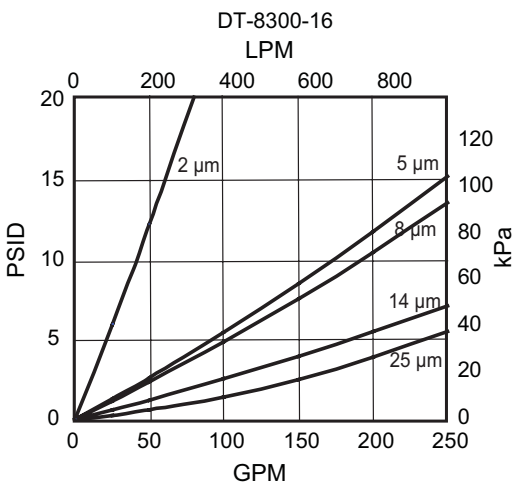
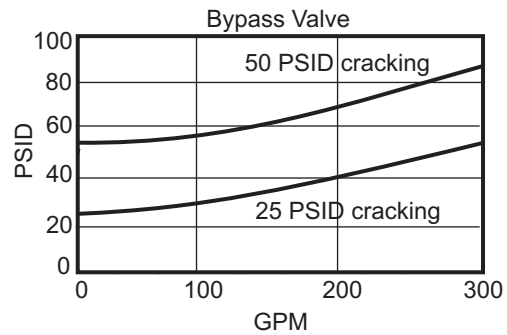
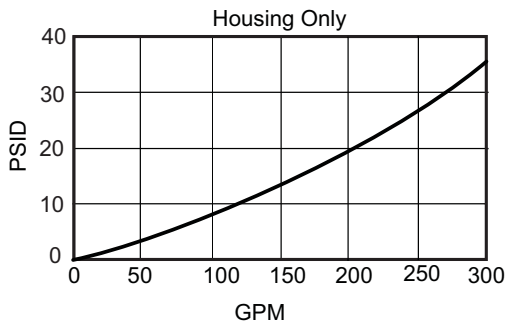

DT-042 Ordering Code



Example

| Model | Housing Length | Bypass Valve | Indicator | Porting | Element Construction | Micron Rating |
|---------------|----------------|--------------|-----------|---------|----------------------|---------------|
| DT-042 | 1 | B | A | K | D | 25 |
| | TABLE 1 | TABLE 2 | TABLE 3 | TABLE 4 | TABLE 5 | TABLE 6 |

Housing shipped without element.

Select one option from each table below.

(See example shown above.)

TABLE 1
Housing Length

| | |
|---|-----|
| 1 | 16" |
| 2 | 39" |

TABLE 2
Bypass Valve

| | |
|---|----------------|
| A | No bypass |
| B | 50 psid bypass |

TABLE 3
Indicator

| | |
|---|---------------------------|
| A | Visual Indicator 35 psid |
| B | Visual Indicator 70 psid |
| C | Visual/Electrical 35 psid |
| D | Visual/Electrical 70 psid |
| N | No indicator |

TABLE 4
Porting

| | |
|---|----------------------|
| K | 3" SAE 4 bolt flange |
|---|----------------------|

TABLE 5
Element Construction

| | |
|---|--------------------------|
| A | Standard (150 psid) |
| D | Extended Life (100 psid) |

Please note: Element selection to be ordered separately.

TABLE 6
Micron Rating

| | |
|----|--------------------------|
| 02 | Beta 1,000 at < 4 micron |
| 05 | Beta 1,000 at 5 micron |
| 08 | Beta 1,000 at 8 micron |
| 14 | Beta 1,000 at 14 micron |
| 25 | Beta 1,000 at 25 micron |

Element Chart

| Length | Construction | Micron Rating | | | | |
|--------|--------------|----------------|----------------|----------------|-----------------|-----------------|
| | | 02 | 05 | 08 | 14 | 25 |
| 1 | A | DT-8300-16-2µm | DT-8300-16-5µm | DT-8300-16-8µm | DT-8300-16-14µm | DT-8300-16-25µm |
| | D | DT-8310-16-2µm | DT-8310-16-5µm | DT-8310-16-8µm | DT-8310-16-14µm | DT-8310-16-25µm |
| 2 | A | DT-8300-39-2µm | DT-8300-39-5µm | DT-8300-39-8µm | DT-8300-39-14µm | DT-8300-39-25µm |
| | D | DT-8310-39-2µm | DT-8310-39-5µm | DT-8310-39-8µm | DT-8310-39-14µm | DT-8310-39-25µm |



Electric Indicator (Aluminum Housings) Schematic Wiring Diagram

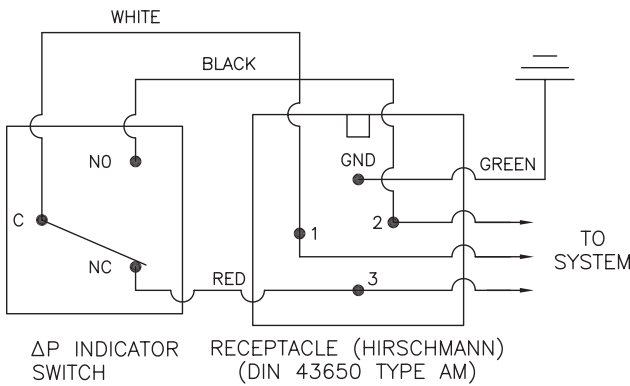

Note: The female plug (connector) is to be furnished by customer

Differential Indicators

Indicators are designed to actuate at approximately 80% of bypass valve cracking pressure. It is recommended that an indicator with a bypass setting of 70 psid is used with a non-bypass housing.

Surge Control

This optional feature is used to dampen pressure surges or spikes to avoid premature actuation of the indicator. Surge control delays the indicator response.

Thermal Lockout

Thermal Lockout (TL), prevents actuation below 60°F and allows actuation above 100°F system operating temperature. Its purpose is to avoid false actuations during periods of high fluid viscosity such as experienced during cold start.

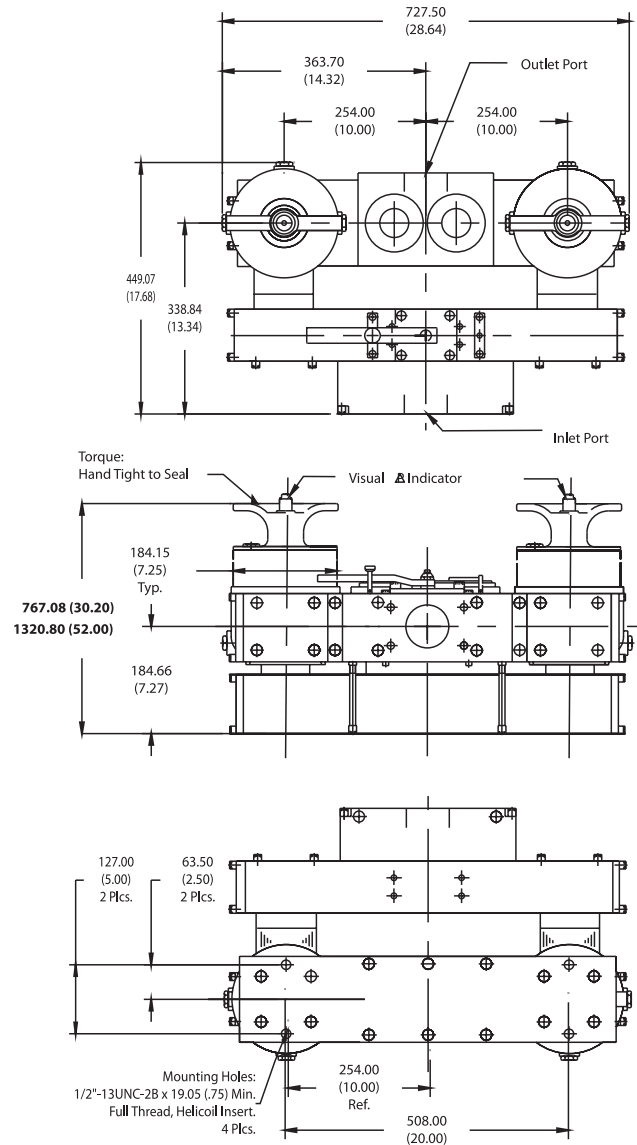

Dimensions: millimeter(inch)