

SP100/120 Spin-On Filters

Working Pressures to: 150 *psi*
1035 kPa
10.3 bar

Rated Static Burst to: 250 *psi*
1725 kPa
17.2 bar

Flow Range to: 100 *gpm*
380 *l/min*



Features

SP100/120 double element head allows for double the flow capacity and a unique, space-saving configuration. Aluminum casting and Buna-N seals standard. SP100/120 elements are interchangeable with SP50/60 filters.

Beta Rating

- Performance to $\beta_{6(c)}=1000$

Porting Sizes

- 1½" NPT

Replacement Filter Lengths

- 6.7" / 170mm
- 7.0" / 178mm
- 10.7" / 271mm

Standard Bypass Ratings

- 25 psi / 172.5 kPa / 1.72 bar

Operating Temperatures

- -22°F to 250°F / -30°C to 121°C

Assembly Weight

- 7.0 lbs (short)
- 8.8 lbs (long)

Assembly - Side View

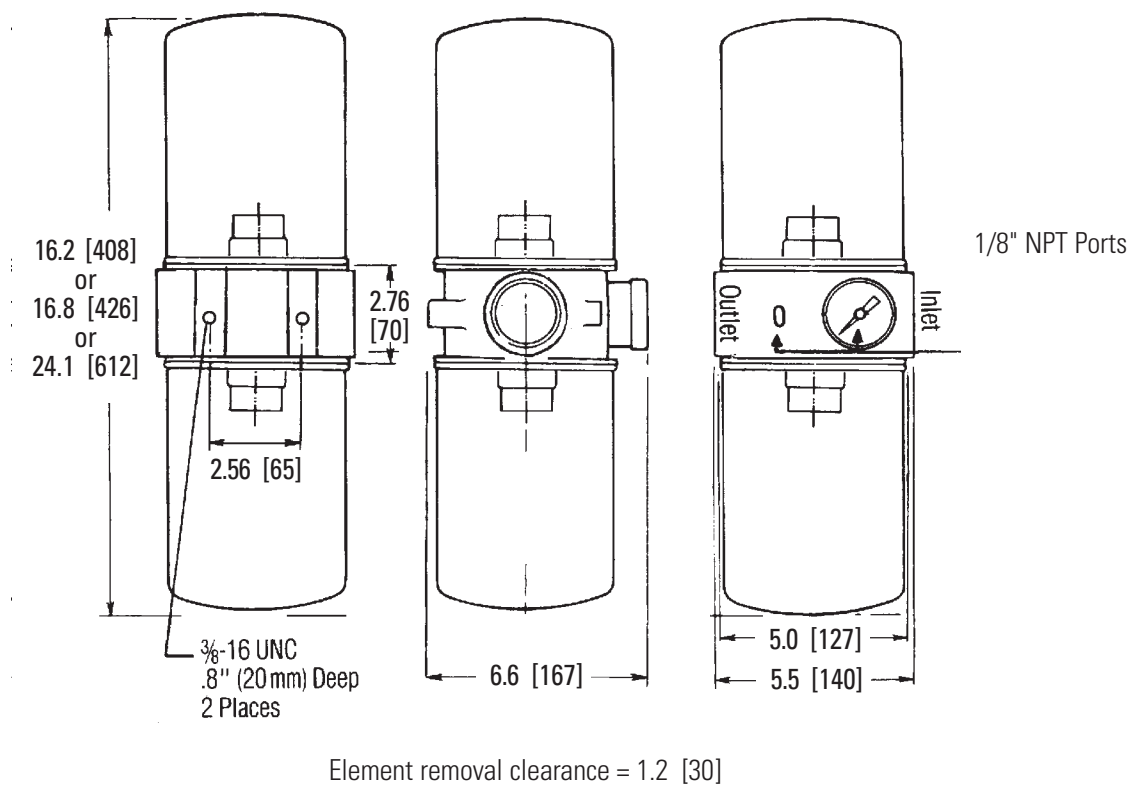

● All dimensions are shown in inches [millimeters]

SP100/120 Components

Element Choices

Media Type	Beta _{x(c)} =200 Rating	Beta _{x(c)} =1000 Rating	Length (in./mm)	Donaldson Part No.	Comments
Cellulose Media #3		24µm	6.7/169	P550386	
Cellulose Media #3		24µm	10.7/271	P550250	
Cellulose Media #10		23µm	6.7/169	P550388	
Cellulose Media #10		23µm	10.7/271	P550251	
Cellulose Media #10		23µm	6.7/169	P562201	
Cellulose Media #10		23µm	7.00/178	P550148	1¼" BSP thread
Cellulose Media #10		23µm	10.7/271	P562204	
Cellulose Media # 3		24µm	6.7/169	P562200	
Beta-10 Absolute Synthetic		10µm	6.7/169	P562207	Synthetic
Beta-10 Absolute Synthetic		10µm	10.7/271	P562208	Synthetic
Beta 3 Absolute Synthetic		6µm	6.7/169	P562209	Synthetic
Beta 3 Absolute Synthetic		6µm	10.7/271	P167832	Synthetic
Cellulose Media #25	32µm		6.7/169	P550387	
Cellulose Media #25	32µm		10.7/271	P550252	
Cellulose Media #25	32µm		6.7/169	P562202	
Cellulose Media #25	32µm		7.0/178	P171616	1¼" BSP thread
Cellulose Media #25	32µm		10.7/271	P562205	
Water Absorbing	10µm water absorption		10.7/271	P561183	Absorbs 24 oz./700 ml water
Wiremesh	150µm nominal		6.7/169	P550275	Stainless Steel
Wiremesh	150µm nominal		10.7/271	P550276	Stainless Steel
Wiremesh	150µm nominal		6.7/169	P562203	

All models have 1½ -16 UNF threads except for P550148 and P171616 which have 1¼" BSP threads.
All models measure 5.0" / 127mm outer diameter.

Head Choices for SP100/120

Port Size	Bypass Rating	Gauge Ports (drill, tap, plug)	Gauge Port Location	DCI Part No.
1½" NPT	25 psi / 172.5 kPa / 1.72 bar	(2) 1/8" NPT	upstream & downstream sides	P563277



Optional Filter Service Indicators

This handy pressure gauge, mounted on the side of an SP100/120 filter head, will tell you when it's time to service the filter element.

Donaldson Part No.	Pressure Range	Use With Bypass Valve Rating	Type
P563978	5 to 30 psi field adj.*	15 psi / 103.4 kPa / 1.34 bar or 25 psi / 172.5 kPa / 1.72 bar or No Bypass	Return indicator, electrical
P563979	-5 to 15 in Hg field adj.*	5 psi / 34.5 kPa / .34 bar or No Bypass	Suction indicator, electrical
P563296	0 to 100 psi	15 psi / 103.4 kPa / 1.34 bar or 25 psi / 172.5 kPa / 1.72 bar or No Bypass	Return indicator, numeric scale
P563297	0 to 100 psi	15 psi / 103.4 kPa / 1.34 bar Bypass	Return indicator, color coded
P563298	0 to 100 psi	25 psi / 172.5 kPa / 1.72 bar or No Bypass	Return indicator, color-coded
P563299	0 to -20 Hg	5 psi / 34.5 kPa / .34 bar or No Bypass	Suction indicator, numeric scale

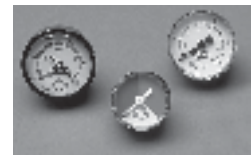
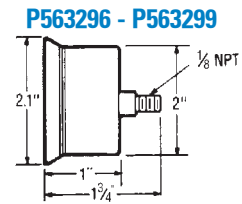

Notes

* NOT PRESET: Setting adjustable for desired application

#1 Common; #2 Normally Closed; #3 Normally Open

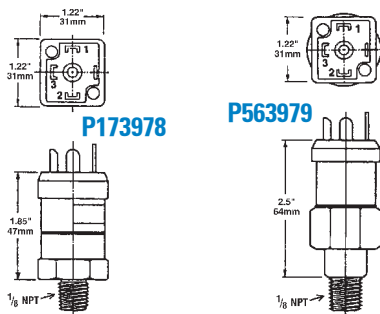

Instructions

1. Remove DIN adaptor
2. Remove small brass screw
3. Using 1/8" allen wrench adjust clockwise to increase set point/counter-clockwise to decrease set point
4. NO / NC

Adjustment screw located in center of elec. prongs

Performance Data

For a full explanation of how our performance curves were derived, see page 150.

SP100

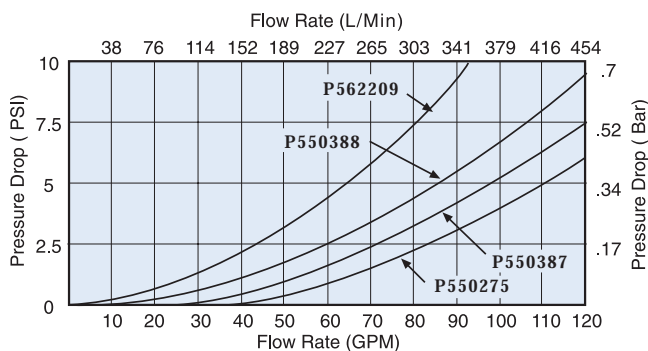

SP120

