

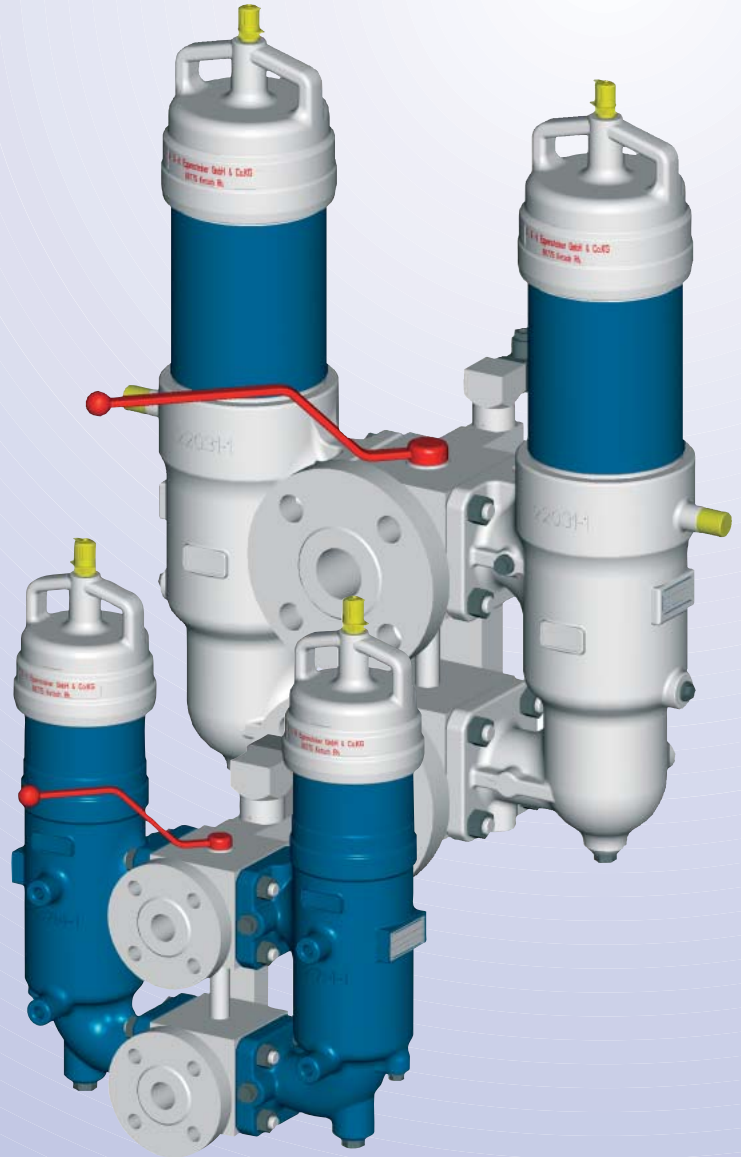

Industrial Filters · Accumulators

Duplex Filters 40 FLDK 0008(C)-0120(C)



*Filters for inline installation
for continuous operating*

Ball valve change - over

*Optimised flow characteristics
by 3D - computer aided design*

Low pressure drop

*Special high efficient
filter media*

*Operating pressure 40 bar
Connections up to DN 80*



Quality assured!

Duplex Filters

40 FLDK 0008(C) - 0120(C)

Operating pressure 40 bar

Operating temperature -10°C to +100°C

Connections up to DN 80

Application

Filtration of pressurised liquids and lubricants.

Filtration of liquids and gases.

Direct installation in pipelines. Direct wear protection of subsequent components and systems.

Continuous operation due to duplex filter design.

Design

Two filter housings in cast iron, connected with a ball valve change-over unit with integrated pressure equalisation.

Connections for inlet and outlet on same side mounted vertically at the filters face.

Material: as per spare parts list in this brochure

Filter Element

Pleated design with optimised pleat density and various filter media. The filter element is the most important component of the filter in view of prolonged life and wear protection of the system.

Oil cleanliness, the initial pressure drop and the dirt holding capacity are the most important criteria for selection.

For further detailed information please refer our "Filter Elements" brochure.

A proper filter selection is enabled by our "EPE - FILTERSELECT" software.

Accessories

Maintenance Indicators

For monitoring the filter element's contamination status, optical and optical/electrical indicators, with one or two switching points are available.

Bypass Valve

To protect the filter element during start up and over pressurisation due to clogging.

Vent Valve

For removing the air from the filter during starting and for safe de-pressurisation.

Performance Characteristics

Oil Viscosity: 30 mm²/s

Specific gravity: < 0.9 kg/dm³

Pressure drop curves for filter assemblies.

Recommended initial Δp pressure drop for filter selection = 0.8 bar

Recommended max. velocity = 3.5 m/s

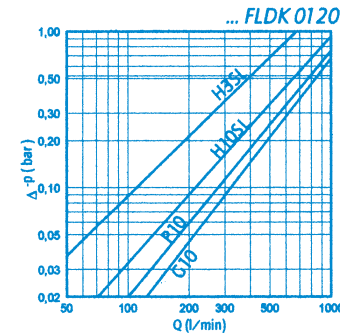
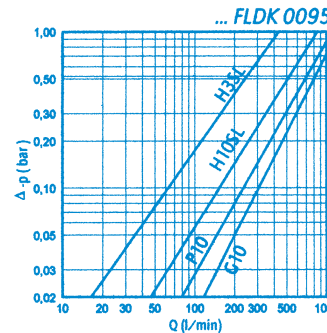
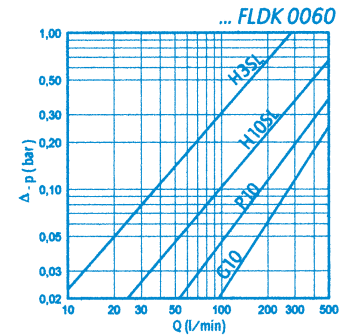
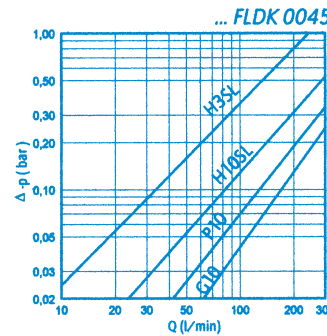
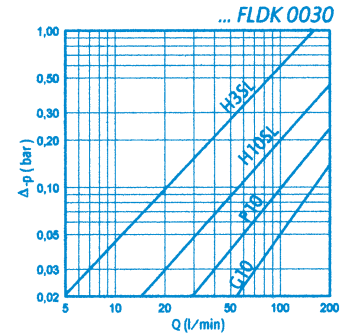
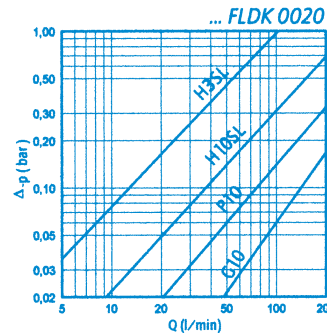
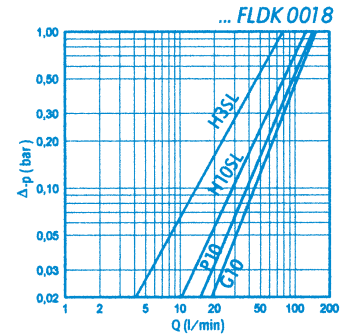
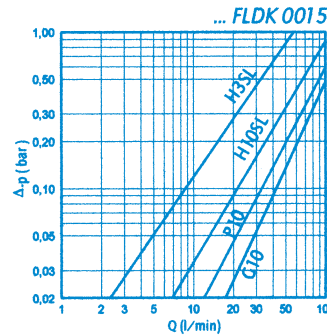
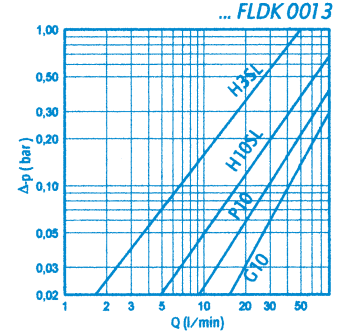
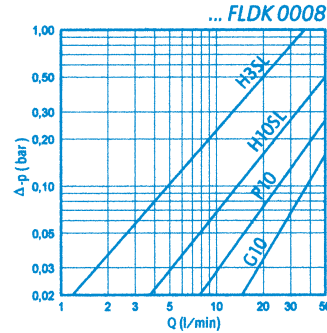

Ordering information

Selection of filter size: using the computer program "EPE - FILTERSELECT" or performance characteristics in this brochure. Special designs available on request.

Type FLDK= Duplex filter with ball valve change-over	Magnet 0 = Without	Maintenance Indicator 0 = Without A = Maintenance indicator visual B = Maintenance indicator visual/electrical with electric plug D = Maintenance indicator visual/electrical with luminous diodes and two switching points Switching pressure: 2.5 bar See illustrations of maintenance indicator for detailed information and technical data!	Connection D0 = DIN-flange	Material 0 = Standard
--	------------------------------	--	--------------------------------------	---------------------------------

Filter Assembly → 40 FLDK 0008 H10SL - A 00 - 0 7 B2,5 - D0 P 0 0

Seal Kit → D 40 FLDK 0008 - B - D0 P 0

Pressure	Size	Filtration Grade	Diff. Pressure	Element Model	Bypass Valve	Seal	Addit. Info
40 bar	0008 (C) 0013 (C) 0015 (C) 0018 (C) 0020 (C) 0030 (C) 0045 (C) 0060 (C) 0095 (C) 0120 (C)	Nominal fineness in µm G = Stainless steel wire mesh, cleanable G10 G25 G40 G60 G80 G100 VS = Nonwoven media, non cleanable VS25 VS40 VS60 P = Paper, not cleanable P5 P10 P25 Absolute filtration grade (ISO 4572) in µm H...SL = Micro glass-fibre, non cleanable H1SL H3SL H6SL H10SL H20SL AS = Micro glass-fibre, water adsorbent, non cleanable AS1 AS3 AS6 AS10 AS20	Max. allowable differential pressure of the filter element A = 30 bar	0... = Standard-adhesive T = 100°C E... = Special-adhesive T = 160°C ...0 = Standard-material ...V = Stainless steel 1.4571	Operating pressure 0 = Without 7 = 3.5 bar Always 0 for filter element	P = Buna N V = Viton E = Ethylene Propylene N = Neoprene	0 = Without 5 = Silicone free E = Vent valve Z = Inspection certificate 5 = Silicone free Z = Inspection certificate

Filter Element → 1. 0008 H10SL - A 00 - 0 - P -

Maintenance Indicator

The maintenance indicator monitors the degree of clogging of the filter elements. They are available as visual or visual/electrical displays. See "Maintenance Indicator" brochure for technical data.

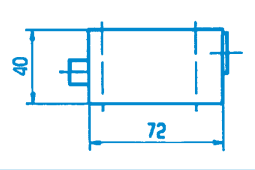
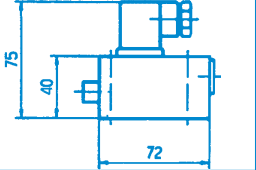
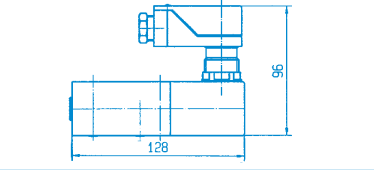
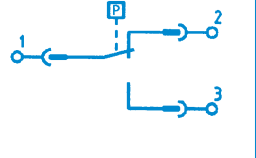
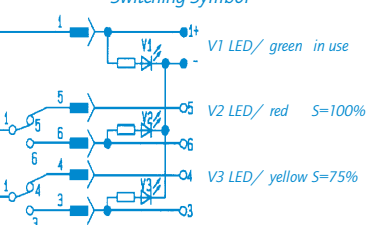
		
A...Visual	B...Visual/Electrical	D...Visual/Electrical with three 24 V diodes and two switching points
Ordering information A2,5 = G2,5 A0 00 00P*	Ordering information B2,5 = G2,5 GW 02 00P*	Ordering information D2,5 = T2,5 GW 09 Z0P*
	Switching Symbol 	Switching Symbol 

Filter Switching Symbol

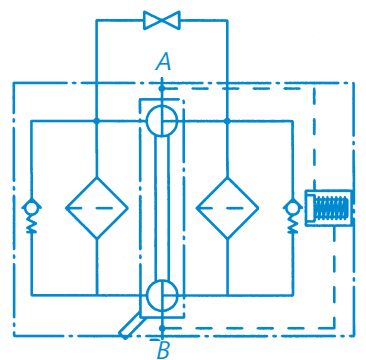

*P = Buna N, V = Viton, E = Ethylene Propylene, N = Neoprene possible

Dimensions

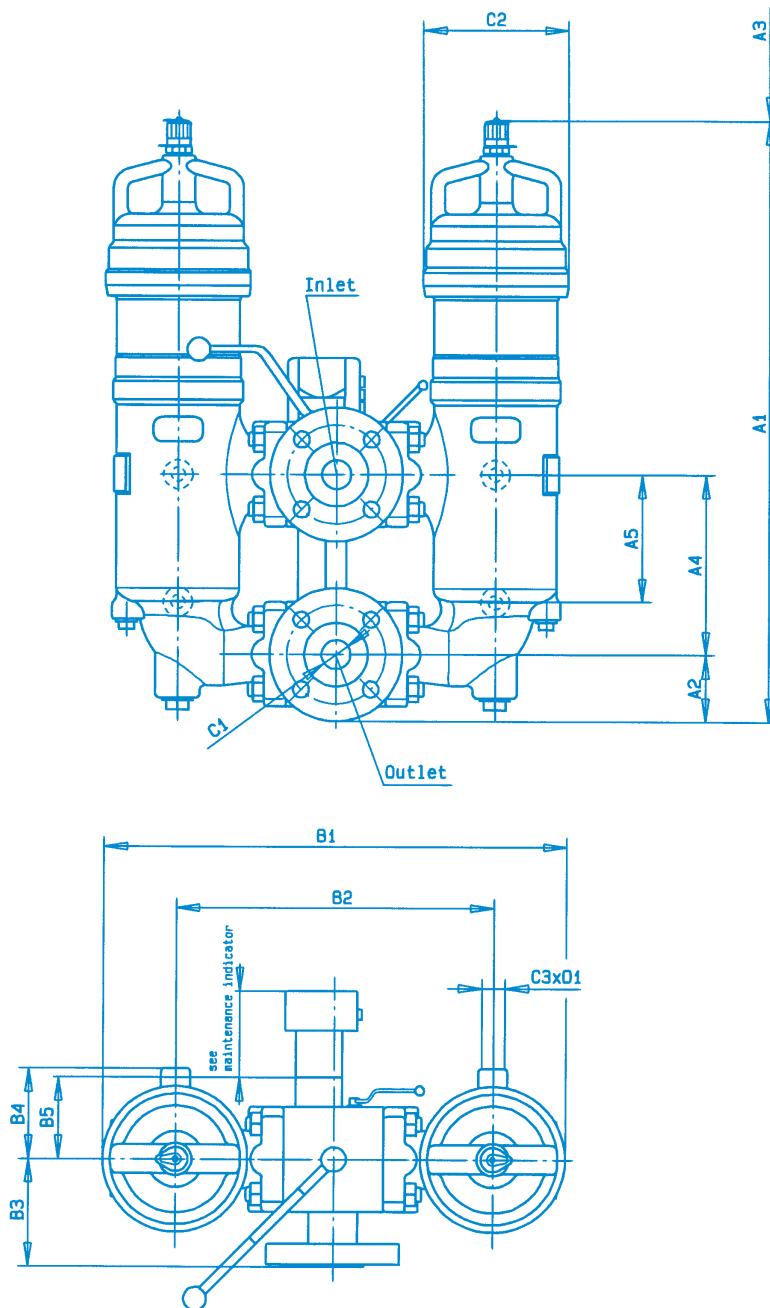

Switch lever indicates operating side

Type	Capacity in l	Weight in kg ¹⁾	A1	A2	A3 ²⁾	A4	A5	B1	B2	B3	B4	B5	C1	C2	C3	D1
40 FLDK 0008 (C)	2 x 1,5	39	416	95	160	155	110	399	274	92.5	77.5	70	DN25	ø125	M12	18
40 FLDK 0013 (C)	2 x 2,0	42	506		250											
40 FLDK 0015 (C)	2 x 1,5	39	416		164											
40 FLDK 0018 (C)	2 x 2,0	42	506		254											
40 FLDK 0020 (C)	2 x 4,0	90	584	70	160	210	210	629	375	149	100	85	DN50	ø158	M16	23
40 FLDK 0030 (C)	2 x 4,0	90	739		250											
40 FLDK 0045 (C)	2 x 6,0	97	739	100	400	230	230	729	484	155	115	130	DN80	ø188	M20	22
40 FLDK 0060 (C)	2 x 9,0	152	686		250											
40 FLDK 0095 (C)	2 x 9,0	152	836		400											
40 FLDK 0120 (C)	2 x 16,0	161	1193		757											

¹⁾ = weight including standard filter element and maintenance indicator

²⁾ = servicing height for filter element replacement

Spare Parts List

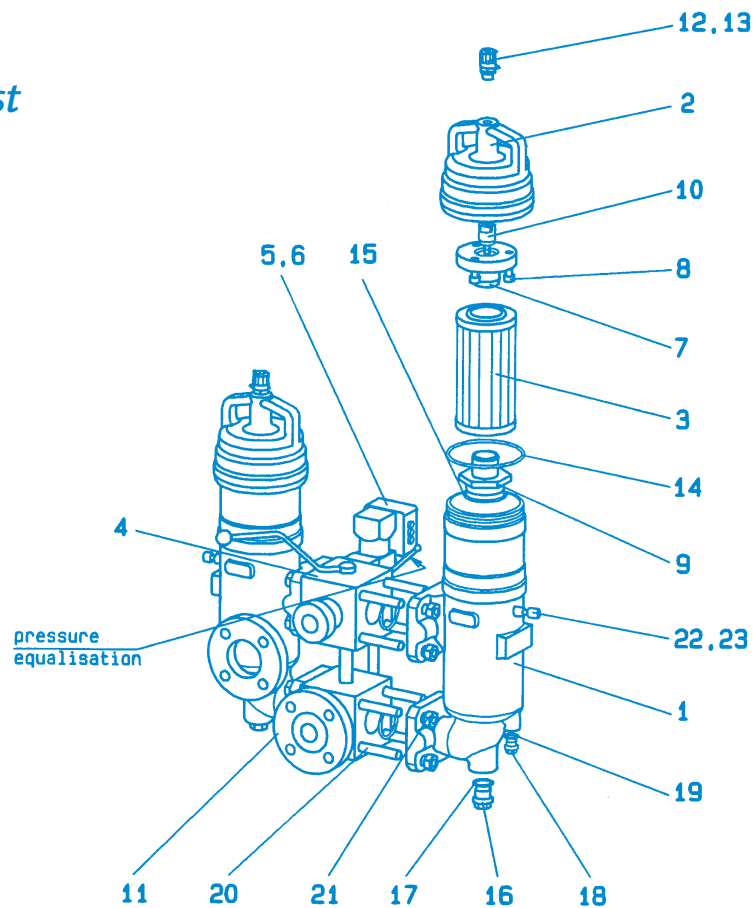

Part	Quantity	Designation	Size	0008(C)	0013(C)	0015(C)	0018(C)	0020(C)	0030(C)	0045(C)	0060(C)	0095(C)	0120(C)		
			Material												
1	2	Filter housing	GGG 50	please indicate ordering information "Filter"											
2	2	Filter head	GkAlSi10Mg	please indicate ordering information "Filter"											
3	2	Filter element	various	please indicate ordering information "Filter Element"											
4	1	Ball valve combination	various	please indicate ordering information "Filter"											
5	1	Maintenance indicator	various	please indicate ordering information "Maintenance Indicator"											
6	2	O-ring	Buna N/Viton	please indicate ordering information "Seal Kit"											
7	2	Filter element locator	AlCuMgPb	please indicate ordering information "Filter"											
8	6	Hexagon head cap screw	8.8	Part No. 637						Part No. 652					
9	2	Filter element locator	AlCuMgPb	please indicate ordering information "Filter"											
10	2	Bypass valve or Blanking plug	various	Part No. 5118				Part No. 5360							
				Part No. 793				Part No. 825							
11	2	DIN flange	C22	Part No. 5204			Part No. 5296			Part No. 4969					
12	2	Measuring connection	various	Part No. 1282											
13	2	Sealing ring	Soft iron	please indicate ordering information „Filter“											
14	2	O-ring	Buna N/Viton	please indicate ordering information „Seal Kit“											
15	2	O-ring	Buna N/Viton	please indicate ordering information „Seal Kit“											
16	2	Blanking plug	St	Part No. 789											
17	2	Sealing ring	Soft iron	please indicate ordering information „Seal Kit“											
18	2	Blanking plug	St	Part No. 770											
19	2	Sealing ring	Soft iron	please indicate ordering information „Seal Kit“											
20	16/32	Stud	8.8	Part No. 9587(16x)				Part No. 9586(16x)				Part No. 9586(32x)			
21	16/32	Hexagon nut	5	Part No. 683(16x)				Part No. 684(16x)				Part No. 684(32x)			
22	2	Arrest screw	various	-										Part No. 4844	
23	2	Sealing ring	Soft iron	-										please ind. ordering inf. „Seal Kit“	

Quality and Standardisation

The development, manufacture and assembly of EPE-industrial filters and filter elements is carried out within the framework of a certified quality-management-system in accordance with DIN EN ISO 9001.

Certification of the filters by accredited institutions (for example TÜV, GL, LRS, LRIS, ABS, BV, DNV, DRIRE, UDT etc.) is available on request.

The stability calculation and testing of the filters proceeds according to existing pressure vessel regulations, as well as in accordance with national and international norms.

The CE - identification mark according to the Pressure Equipment Directive 97/23/EG depends upon the individual application and operating conditions. On request we will classify the filters.



Industrial Filters · Accumulators

Installation, Starting and Maintenance

Filter Installation

Verify operating pressure with name plate information.
Mount the filter housing Part 1 using mounting device considering flow direction (direction arrows) and servicing height required for cleaning/replacing filter elements.

Connection of Electrical Maintenance Indicator

See brochure 64
and list acc. this brochure

Starting

Switch on system pump. Open pressure equalisation.
De-aerate filter by opening the vent valve Part 12, close when liquid emerges from valve. Leave pressure equalisation open.

Maintenance

The filter element is clogged and must be changed or cleaned when at operating temperature the red pointer on the maintenance indicator Part 5 is hard against the plastic cap and/or the switching process on the electrical indicator is triggered.

Filter Element Service

Operate switching lever and switch to filter housing out of service.
Close pressure equalisation.
De-pressurise filter out of service by opening vent valve Part 12 one turn. Open plugs Part 16 + Part 18 and drain contaminated oil.
Unscrew filter head Part 2. Remove filter element Part 3 from filter housing Part 1 turning slightly off from its locator in the filter lower part. Close plugs Part 16 + Part 18 and vent valve Part 12. Control cleanliness of filter housing.
Replace filter element H... SL, VS..., AS... and P... , the filter element with G... media is cleanable. The efficiency of the cleaning process depends on the characteristics of contamination and the final pressure drop prior to servicing/cleaning the element. If the differential pressure after the filter element's cleaning process exceeds more than 50% of the pre service value the G... element also needs to be replaced.
Lubricate filter element O-ring and install replaced or cleaned filter element inside filter housing by putting it up to its locator and slightly turning. Take care not to damage pleated filter element matrix during installation in filter housing. Check O-ring Part 14 in filter head, replace in case of damage or wear. Screw on filter head without using a tool until the end of the thread. Turn it back $\frac{1}{4}$ thread turn.
Open pressure equalisation. De-aerate filter by opening the vent valve Part 12, close when liquid emerges from valve. Leave pressure equalisation open.

Warning

Assemble and disassemble filter only when system is switched off!
Vessel is under pressure!
Leave pressure equalisation valve closed while filter housing is out of service!
Do not operate switching device while filter housing is out of service!
Do not change maintenance indicator or pressure equalisation valve when filter is under pressure!
Functions and safety warranty only with EPE-spare part!
Service filter only by trained personal!

Technical modifications reserved!