



Industrial Filters · Accumulators

## Duplex Filters

40/160 LD 0003 - 0045

40/160 LDN 0040 - 0400

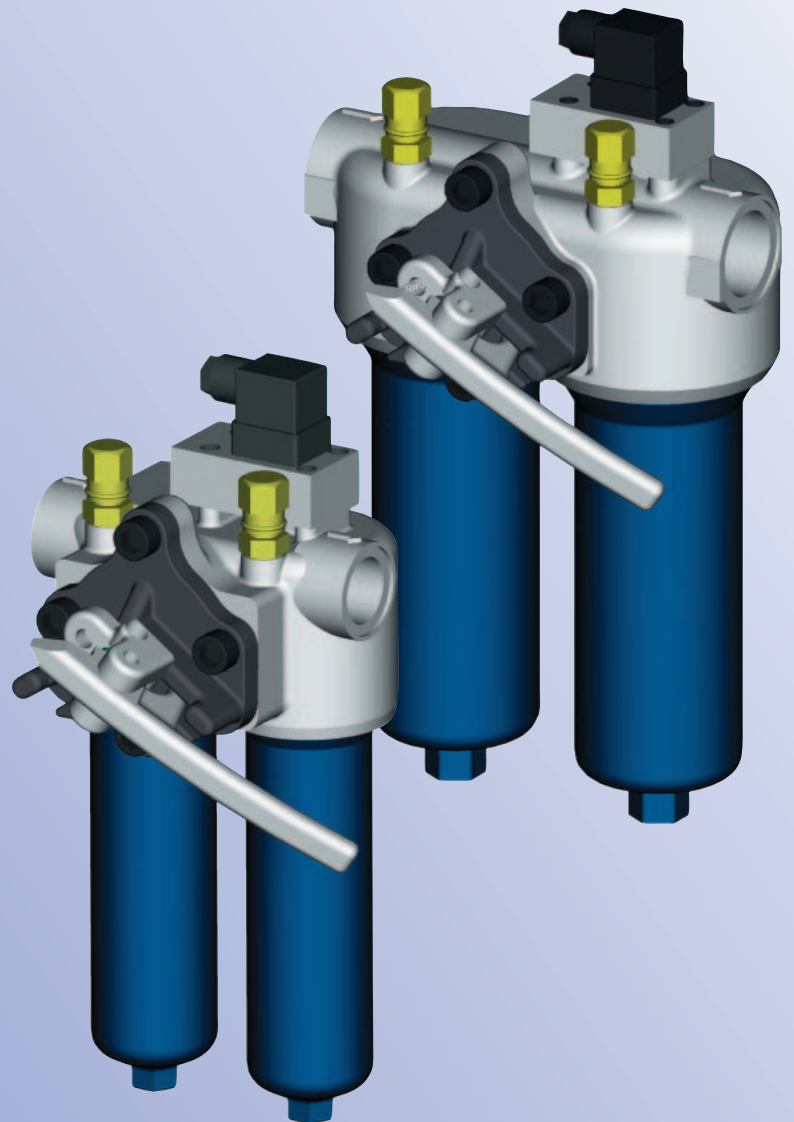

*Filters for inline installation  
for continuous operation*

*With integrated pressure  
equalisation valve*

*Optimised flow characteristics  
by 3D - computer aided design*

*Low pressure drop*

*Special high efficient  
filter media*

*Operation pressure 40/160 bar  
Connection up to SAE 1½"*



Quality assured!

## Duplex Filters

40/160 LD 0003 - 0045  
40/160 LDN 0040 - 0400

Operating pressure 40/160 bar  
Operating temperature -10°C to +100°C  
Connection up to SAE 1 1/2"

### Application

Filtration of hydraulic fluids and lubricants.  
Filtration of liquids.  
Direct installation in pipelines to provide wear protection of subsequent components and systems.

### Design

Filter Head with inlet & outlet ports and spigots to locate filter elements.  
Screwed Filter Bowl.  
Materials: See spare parts list in this brochure.

### Filter Element

Pleated design with optimal pleat density and various filter material.  
The filter element is the most important part of the system "Filter" with respect to availability and corrosion protection for the installation.

The deciding factors for selection are the degree of purity of the operating medium, the initial differential pressure, and the dirt retaining capacity.

Further details can be found in our brochure "Filter Elements".

Our computer programme "EPE-FILTERSELECT" enables an optimal filter selection.

### Accessories

#### Maintenance Indicator

These monitor the degree of clogging of the filter elements and are available as visual or visual/electric displays with one or two shift points.

#### Bypass Valve

For the protection of the filter elements during cold start and when the differential pressure is exceeded due to clogging.

#### Vent Valve

For venting air from the filter during start up and for safe depressurisation.

## Performance Characteristics

$\Delta p$ -Q-characteristic lines for complete filters recommended start- $\Delta p$  for layout = 0.8 bar  
recommended velocity for layout = 3.5 m/s

Oil Viscosity: 30 mm<sup>2</sup>/s  
Specific gravity < 0.9 kg/dm<sup>3</sup>

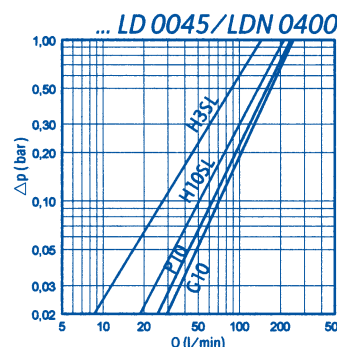
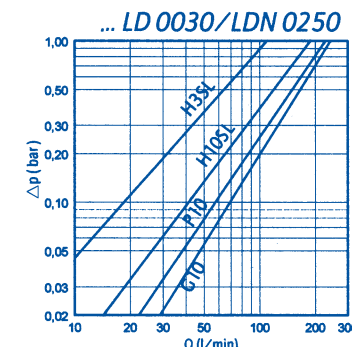
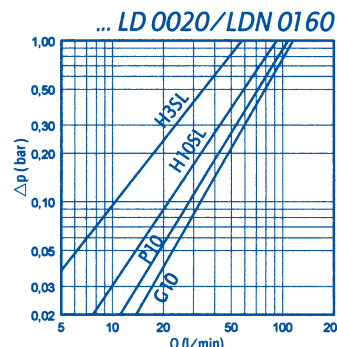
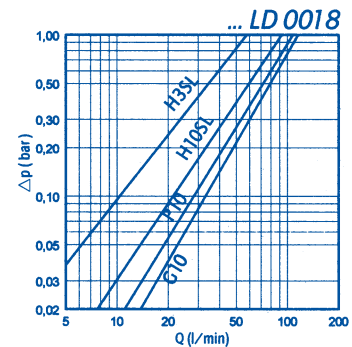
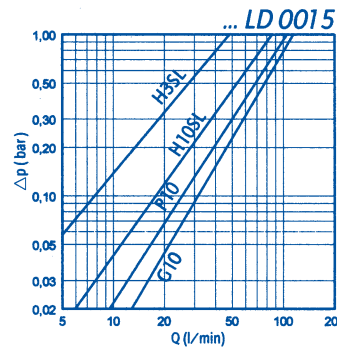
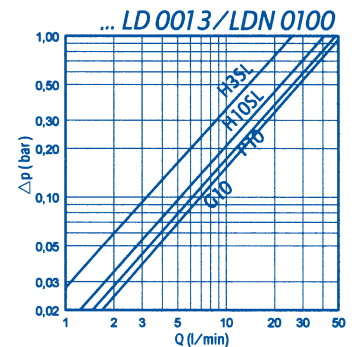
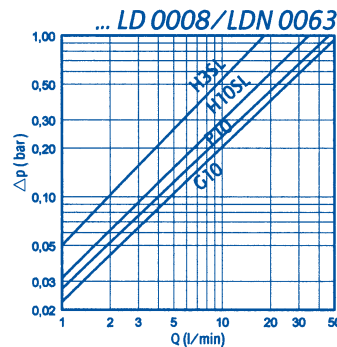
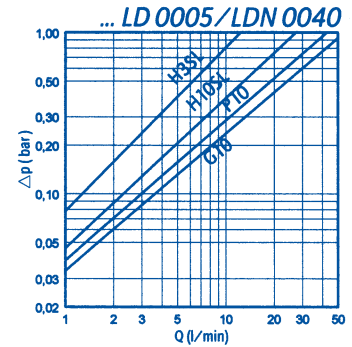
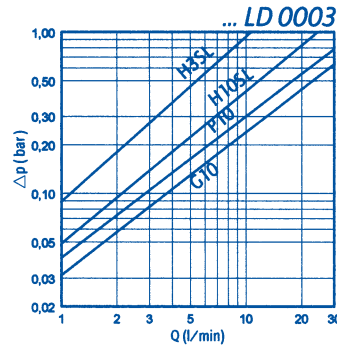

## Ordering code

Identification of filter size:  
Using the computer  
programme  
"EPE-FILTERSELECT" or the  
performance characteristic  
lines in this brochure.  
Special models are available  
on request

Type	Magnet	Maintenance Indicator	Connection	Material
LD = duplex filter with filter element according to EPE Standard  LDN = duplex filter with filter element according to DIN 24550	0 = without	0 = without A = Maintenance visual B = Maintenance visual/elect. with equipment connector thread D = Service display visual/elect. with luminous diodes and two shift points  Enter switching pressure: 2,5 bar for 40 LD and LDN 5,0 bar for 160 LD and LDN  See illustrations of maintenance indicator for detailed information and technical data.	00 = pipe thread  50 = SAE-flange	0 = Standard

Filter → 160 LD 0013 H10SL - A 00 - 0 9 D5,0 - 00 P 0 0  
Seal Kit → D 160 LD 0013 - - D - 00 P 0

Pressure	Size	Filtration Grade	Diff. Pressure	Element Model	Bypass Valve	Seal	Addit. Info
40 bar 160 bar	40/160 LD... 0003* 0005 0008 0013 0015 0018 0020 0030 0045	Nominal filter fineness in µm G = Stainless steel meshing, cleanable G10 G25 G40 G60 G80 G100 VS = bonded fabric, not cleanable VS25 VS40 VS60 P = Paper, not cleanable P5 P10 P25  Absolute filter to (ISO 4572) in µm H...SL = Microglass, not cleanable H1SL H3SL H6SL H10SL H20SL AS = Microglass, water-absorbent, not cleanable AS1 AS3 AS6 AS10 AS20	Max. allowable differential pressure of the filter element  A = 30 bar B = 330 bar	0... = Standard-adhesive T = 100°C  E... = Special-adhesive T = 160°C  ...0 = Standard material ...Z = Free of zinc	opening pressure 0 = Without 7 = 3,5 bar for 40 LD and 40 LDN 9 = 7,0 bar for 160 LD and 160 LDN  Always 0 for filter element	P = Buna N V = Viton E = Ethylene-propylene N = Neoprene	0 = without 5 = silicon free E = ventilation valve Z = inspection certificate  5 = silicon free Z = inspection certificate

Filter Element → 2. 0013 H10SL - A 00 - 0 - P -

## Maintenance Indicator

The maintenance indicator monitors the degree of clogging of the filter elements.  
They are available as visual or visual/electrical displays.  
See "Maintenance Indicator" brochure for technical data.

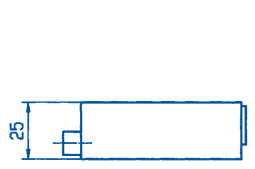
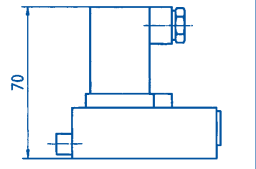
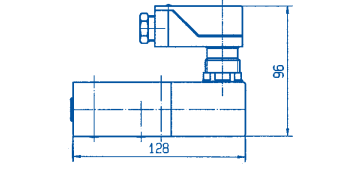
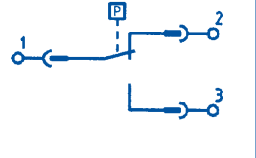
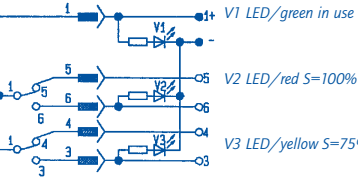
		
A...Optical	B...Optical/electrical	D...Optical/electrical with three 24 V diodes and two switch points
Ordering information A2,5 = F2,5 A0 00 00P* A5,0 = F5,0 A0 00 00P*	Ordering information B2,5 = F2,5 GW 02 00P* B5,0 = F5,0 GW 02 00P*	Ordering information D2,5 = R2,5 GW 09 ZOP* D5,0 = R5,0 GW 09 ZOP*
	Switch Symbol 	Switch Symbol 

## Filter Switching Symbol

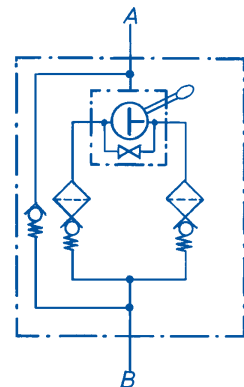

\*P = Buna N; V = Viton; E = Ethylene Propylene; N = Neoprene possible

## Dimensions

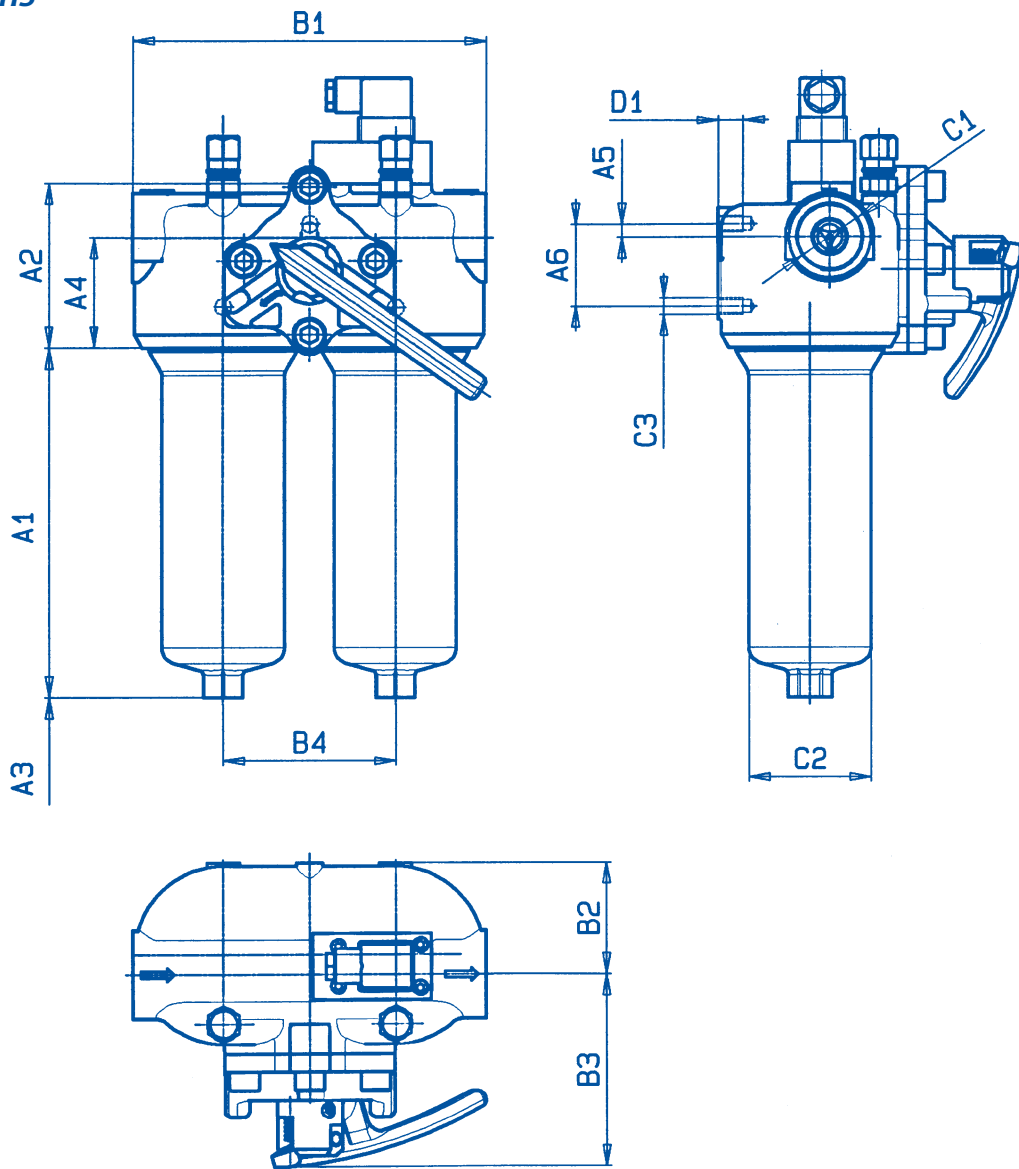

### Filter housing for filter element in accordance with EPE standard

Type	Capacity in l	Weight in kg <sup>1)</sup>	A1	A2	A3 <sup>2)</sup>	A4	A5	A6	B1	B2	B3	B4	C1 Connection	C2	C3	D1
40/160 LD 0003	2 x 0,23	6,8	115	102	80	70	8	50	160	54	115	80	G1	55	M10	15
40/160 LD 0005	2 x 0,23	7,0	115		100											
40/160 LD 0008	2 x 0,36	7,5	179		120											
40/160 LD 0013	2 x 0,53	8,8	269	67		10	50	215	68	120	105	G1¼	76	M12	18	
40/160 LD 0015	2 x 0,80	13,2	213													100
40/160 LD 0018	2 x 0,99	16,3	263	116		81	17	55	270	102	115	134	G1½	104	M16	24
40/160 LD 0020	2 x 1,19	19,0	188													
40/160 LD 0030	2 x 1,76	20,0	276													
40/160 LD 0045	2 x 2,72	23,0	426	116	81	17	55	270	102	115	134	G1½	104	M16	24	

### Filter housing for filter element in accordance with DIN 24550

Type	Capacity in l	Weight in kg <sup>1)</sup>	A1	A2	A3 <sup>2)</sup>	A4	A5	A6	B1	B2	B3	B4	C1 Connection	C2	C3	D1
40/160 LDN 0040	2 x 0,23	7,0	115	102	100	70	8	50	160	54	115	80	G1	55	M10	15
40/160 LDN 0063	2 x 0,36	7,5	179		120											
40/160 LDN 0100	2 x 0,53	8,8	269													
40/160 LDN 0160	2 x 1,19	19,0	188													
40/160 LDN 0250	2 x 1,76	20,0	276	SAE 1½"3000 psi	104	M16	24									
40/160 LDN 0400	2 x 2,72	23,0	426													

<sup>1)</sup> = Weight including standard filter element and maintenance indicator

<sup>2)</sup> = Construction dimension for filter element change

## Spare Parts List

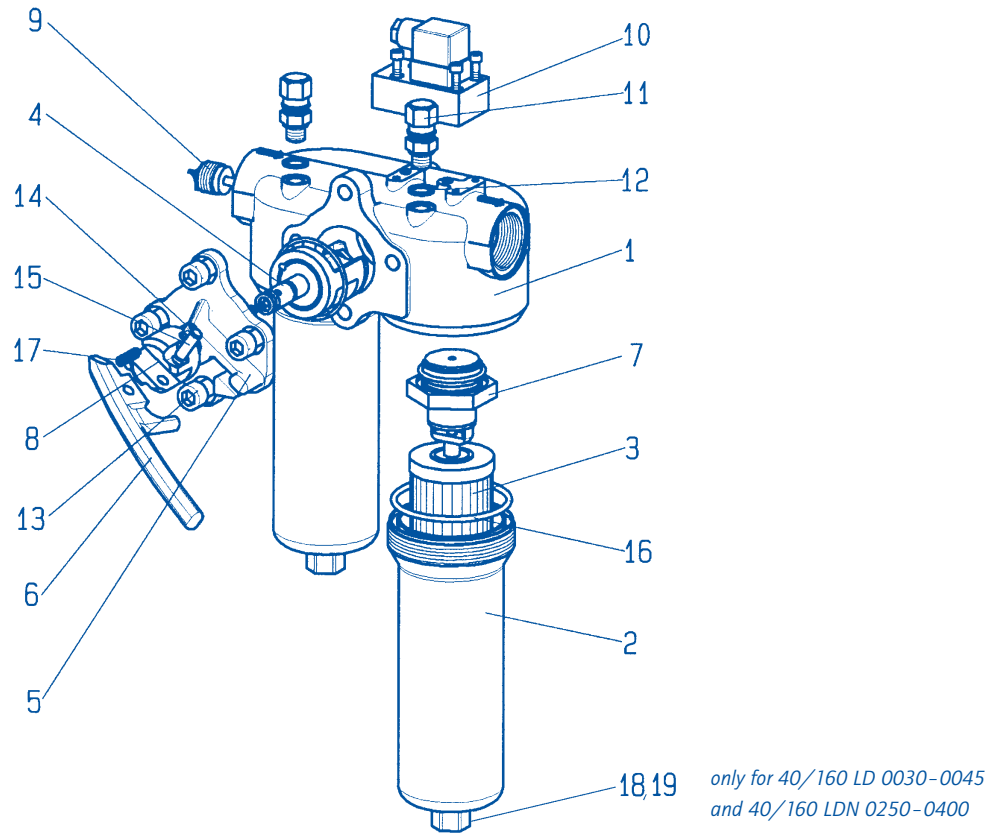

Switch lever indicates the side of maintenance.

		Size LD		0003	0005	0008	0013	0015	0018	0020	0030	0045
		Size LDN			0040	0063	0100			0160	0250	0400
Part	quantity	Title	Material	please indicate ordering information								
1	1	Filter head	GGG50	"Filter"								
2	2	Filter bowl	C-steel	"Filter"								
3	2	Filter element	various	"Filter Element"								
3.1	1	O-ring	Buna N/Viton	"Seal Kit"								
4	1	Change over valve	various	Part No. 3617 (with filter head only)								
4.1	1	O-ring	Buna N/Viton	"Seal Kit"								
4.2	1	Wiper	Buna N	"Seal Kit"								
4.3	1	O-ring	Buna N/Viton	"Seal Kit"								
5	1	Cover	GGG50	Part No. 3616								
6	1	Switch lever	Al Si 9 Mg	Part No. 3618								
7	2	Return valve	various	Part No. 5195			Part No. 5161			Part No. 3619		
7.1	1	O-ring	Buna N/Viton	"Seal Kit"								
7.2	1	O-ring	Buna N/Viton	"Seal Kit"								
8	1	Bolts	9SMn28K	Part No. 3630								
9	1	Bypass valve*	various	Part No. 5358				Part No. 5118				
10	1	Maintenance indicator	various	"Maintenance Indicator"								
11	2	Vent valve	Bronze	Part No. 848								
12	2	Sealing ring	Soft iron	"Seal Kit"								
13	4	Hexagon screw	8.8	Part No. 4971								
14	2	Hexagon screw	8.8	Part No. 5119								
15	1	Parallel pin	St	Part No. 3631								
16	2	O-ring	Buna N/Viton	"Seal Kit"								
17	1	Spring	Spring steel	Part No. 3201								
18	2	Drain plug	5.8								Part No. 770	
19	2	Sealing ring	Soft iron								please indicate ordering information "Seal Kit"	

\* please specify operating pressure

## Quality and Standardisation

The development, manufacture and assembly of EPE-industrial filters and filter elements is carried out within the framework of a certified quality management system in accordance with DIN EN ISO 9001.

The stability calculation and testing of the filters proceeds according to actual standards, as well as in accordance with national and international norms.

The CE-identification mark according to the Pressure Equipment Directive 97/23/EG depends upon the individual application and operating conditions. On request we will classify the filters.

Certification of the filters by accredited institutions (for example TÜV, GL, LRS, ABS, BV, DNV, DRIRE, UDT, etc.) is available on request.



Industrial Filters · Accumulators

## **Installation, Starting Maintenance**

### **Installation**

Check that the pressure rating of the filter is suitable for the system in which it is being installed.

Screw the filter head (Part 1) onto the mounting device, taking into account the direction of flow (directional arrow) and installation height of the filter element (Part 3).

Remove filter entry and exit plugs, screw filter into the pipe-line, taking care to avoid stress on the components.

### **Connection of electrical maintenance indicator**

Connect using three pole cable, paying attention to breaking capacity on the rating plate of the filter (Part 10).

Connection variants:

- |            |                                  |
|------------|----------------------------------|
| 1. Closer  | 1 (black) + 3 (blue)             |
| 2. Opener  | 1 (black) + 2 (brown)            |
| 3. Changer | 1 (black) + 2 (brown) + 3 (blue) |

### **Starting**

Switch on service pump

Ventilate filter by opening the vent valve (Part 11), close when operating liquid appears.

Switch lever indicates the side of maintenance.

### **Maintenance**

The filter element is clogged and must be changed or cleaned when at operating temperature the red pointer on the Maintenance indicator (Part 10) is hard against the plastic cap. and/or the switching process on the electrical indicator is triggered.

### **Filter Element Service**

Pull the switch-over lever and switch over to the second filter.

Open the vent valve (Part 11) on the filter half taken out of operation and reduce the pressure.

Unscrew the filter (Part 2) and remove the filter element (Part 3) with slight rotation, from the centering spigot on the filter head.

Check the filter head for cleanliness and clean if necessary.

Replace filter elements H ... -SL, P ... and VS ... Clean the filter element with material G ...

The effectiveness of cleaning is dependent on the type of dirt and the level of the differential pressure at the time of changing the filter element.

If the differential pressure is more than 50 % of the value obtaining before the filter change, then the element G ... is to be replaced.

Using a light rotation movement, place new or cleaned filter elements on the centering spigot.

Check O-ring (Part 16) in the filter housing and replace when damaged or worn.

Screw on the filter head and tighten the hexagon with appropriate tool.

Put back into operation as described above.

### **Information**

When disassembling the filters make sure that the filter inlet and outlet are drained separately!

Technical specification are subject to change!